

# Airflow Meters

## Stationary and Panel Mounted



---

### Performance Specifications

---

**Accuracy.** Rated at 70°F,  $\pm 2.0\%$  for 1.0" to 6.0" w.c. range;  $\pm 3.0\%$  for 0.50" w.c. range;  $\pm 4.0\%$  for 0.25" w.c. range.

**Temperature Limits.** 20°F to 140°F Operating.

**Overpressurization Limit.** -20" Hg to 15 psig on either side of diaphragm.

---

### Features

---

**Ease of Installation.** Factory mounted, pre-tubed and calibrated for ease of field installation. Customer specified signal connection fittings included.

**Indication.** Each meter serves as a visual monitor of the HVAC system and fan operation. Can indicate slipping or broken fan belts, fan off due to overload, closed fire dampers, failing fan bearing, open access door, erratic controls performance, etc.

**Custom Scaling.** Meter faces custom scaled in user selectable volume, velocity, and/or pressure engineering units of measure.

**Identification Label.** Each meter is provided with an application specific, engraved, plastic data plate stating the system, the airflow station number, and the maximum meter range.

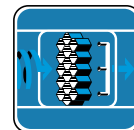

AIR MONITOR  
CORPORATION

# Airflow Meters

## Construction Features

### Stationary Meter

**Type.** Stationary.

**Gauge.** Diaphragm activated, differential pressure.

**Enclosure.** Anodized aluminum, NEMA 1.

**Signal Fittings.** Standard barbed fittings for 1/4" O.D. tubing. Other fittings available.

**Display.** Custom, dual scaled display of process.

### Meter Panel

**Type.** Door mounted (minimum of two meters per panel).

**Gauge.** Diaphragm activated, differential pressure.

**Enclosure.** NEMA 1 steel with polyurethane paint finish.

**Signal Fittings.** Standard barbed fittings for 1/4" O.D. tubing. Other fittings available.

**Display.** Custom, dual scaled display of process.

## Dimensional Specifications

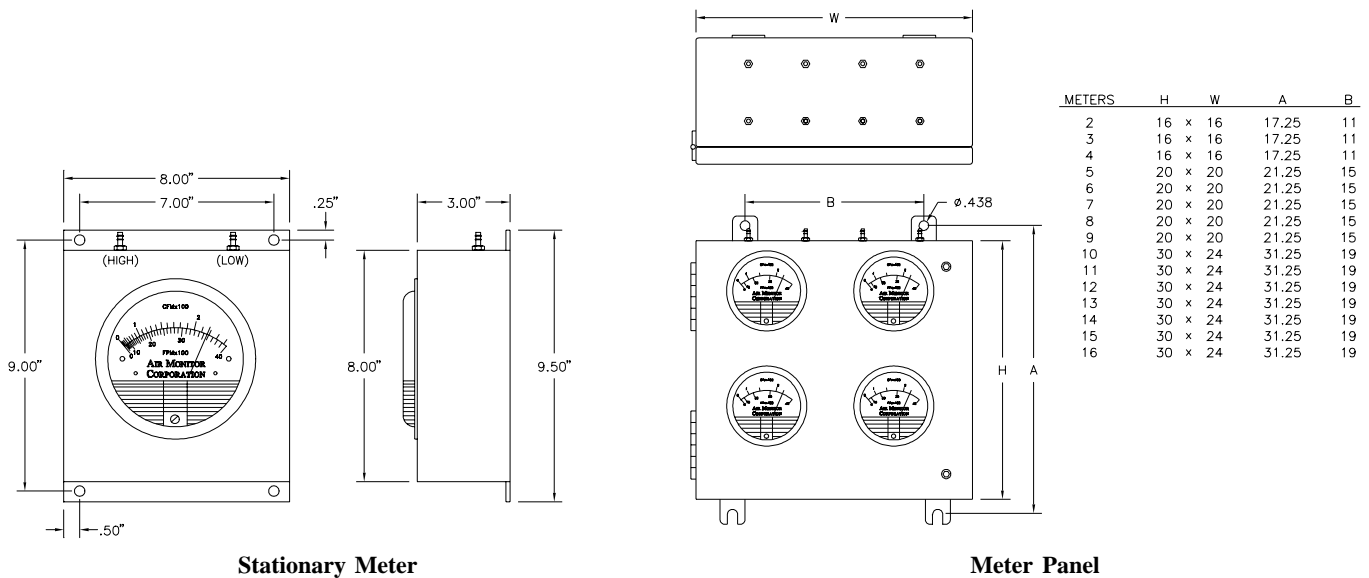

Stationary Meter

Meter Panel

## Suggested Specification

**Stationary Meter.** Provide where indicated a stationary meter consisting of a dual-scale, diaphragm-actuated, differential pressure gauge mounted in an anodized aluminum enclosure. Gauges to be custom scaled to read in user selected volume, velocity, and/or pressure units of measure. Meter to be complete with internal tubing, [specify type] signal connection fittings, wall mounting brackets, and furnished with a plastic data plate listing the system, the airflow station number, and the maximum scheduled air volume.

The meter shall be the Stationary Meter as manufactured by Air Monitor Corporation, Santa Rosa, California.

**Meter Panel.** Provide where indicated a meter panel consisting of multiple dual-scale, diaphragm-actuated, differential pressure gauges mounted in a NEMA 1 steel enclosure. Gauges to be custom scaled to read in user selected volume, velocity, and/or pressure units of measure. Meter to be complete with internal tubing, [specify type] signal connection fittings, wall mounting brackets, and furnished with a plastic data plate listing for each gauge, the system, the airflow station number, and the maximum scheduled air volume.

The central panel shall be the Meter Panel as manufactured by Air Monitor Corporation, Santa Rosa, California.

